



User Manual

110101

Lever Dispenser
with 3 Ltr. Stainless Steel
Locksafe Container



①

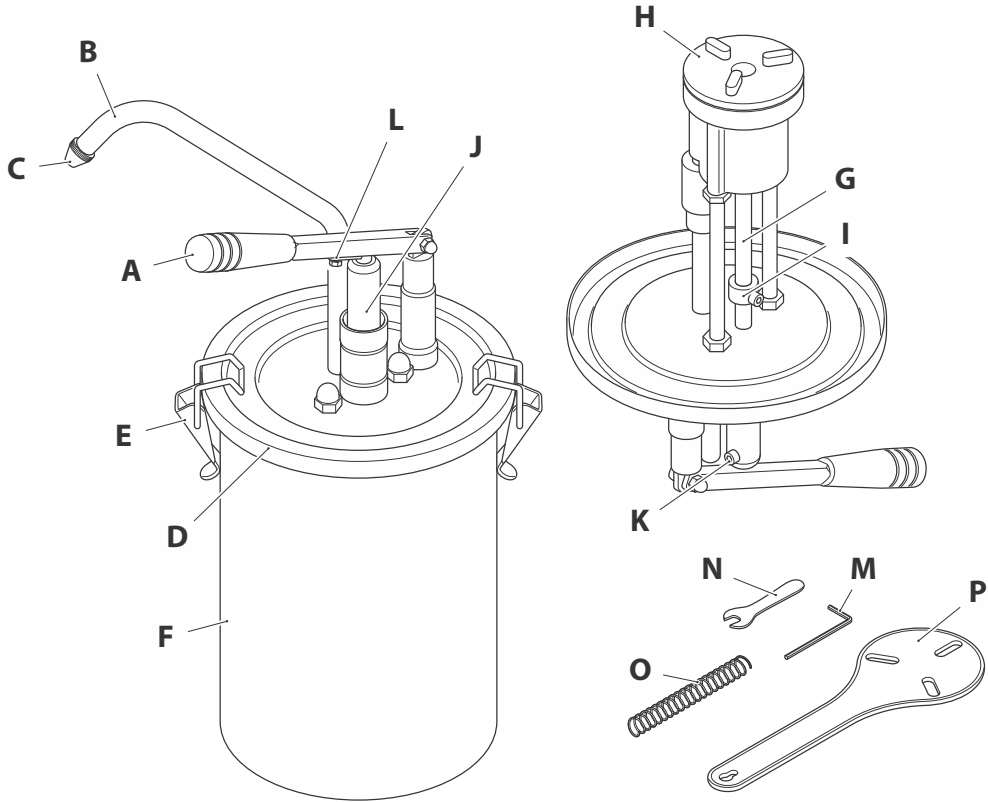

②

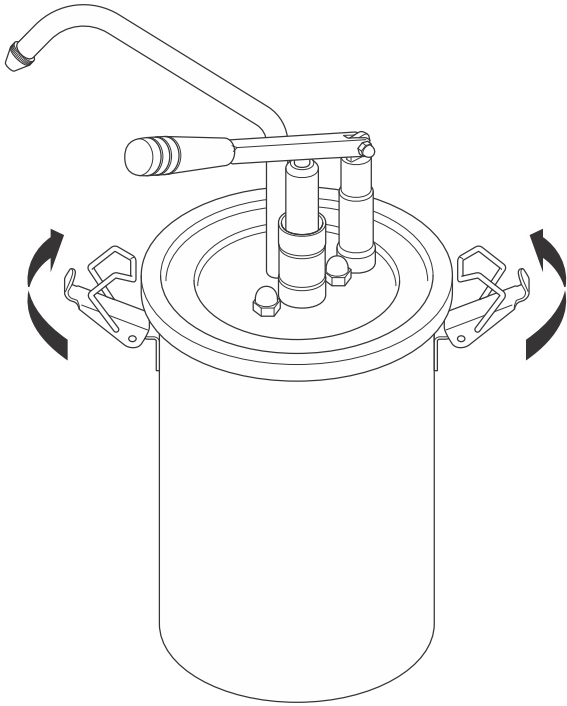

③

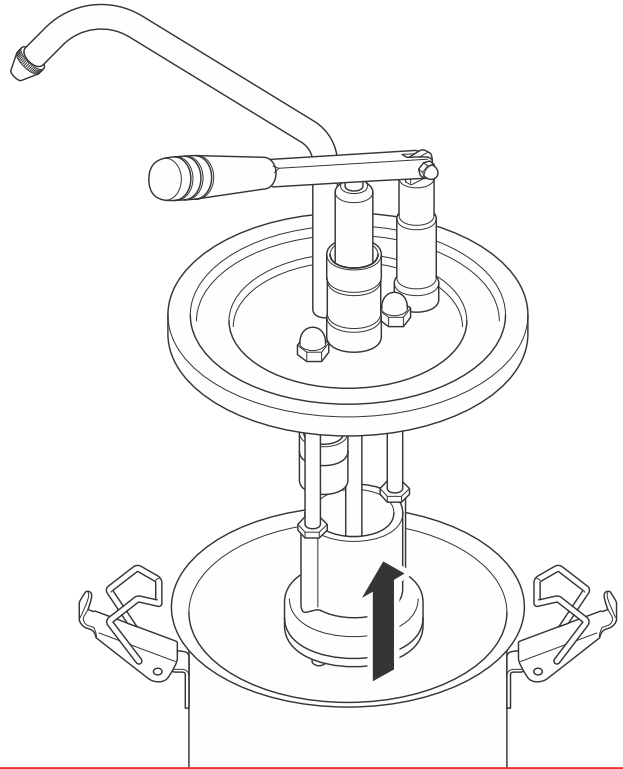

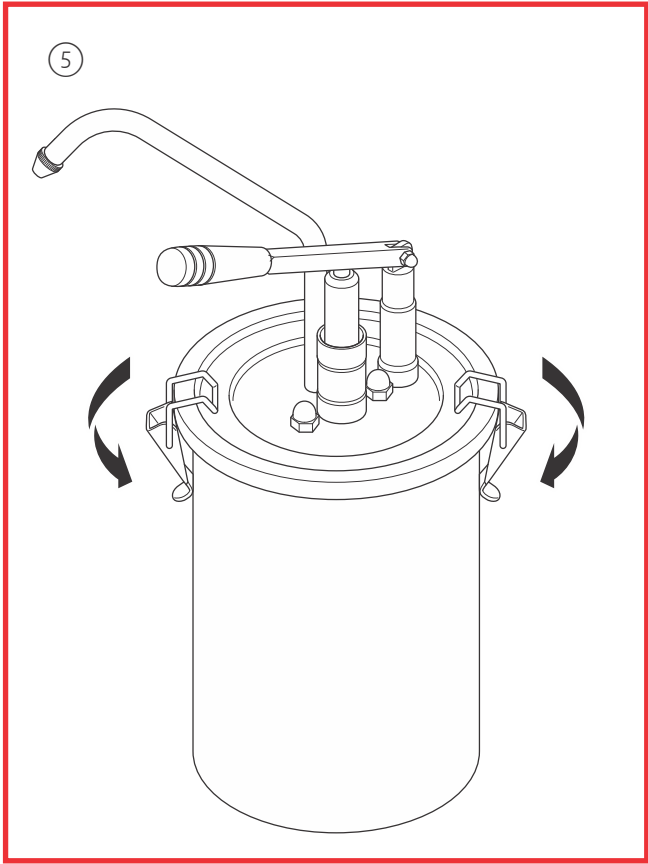
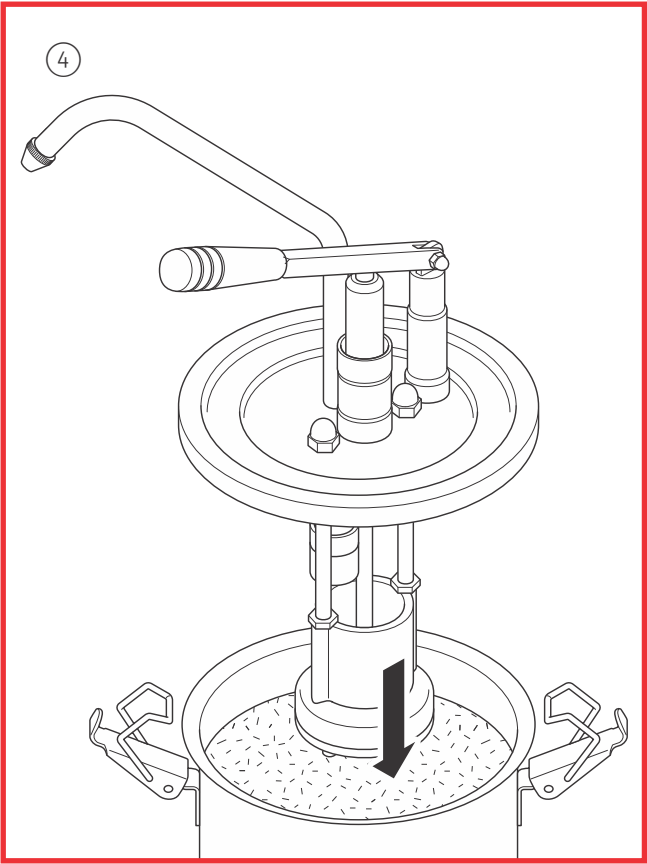

6

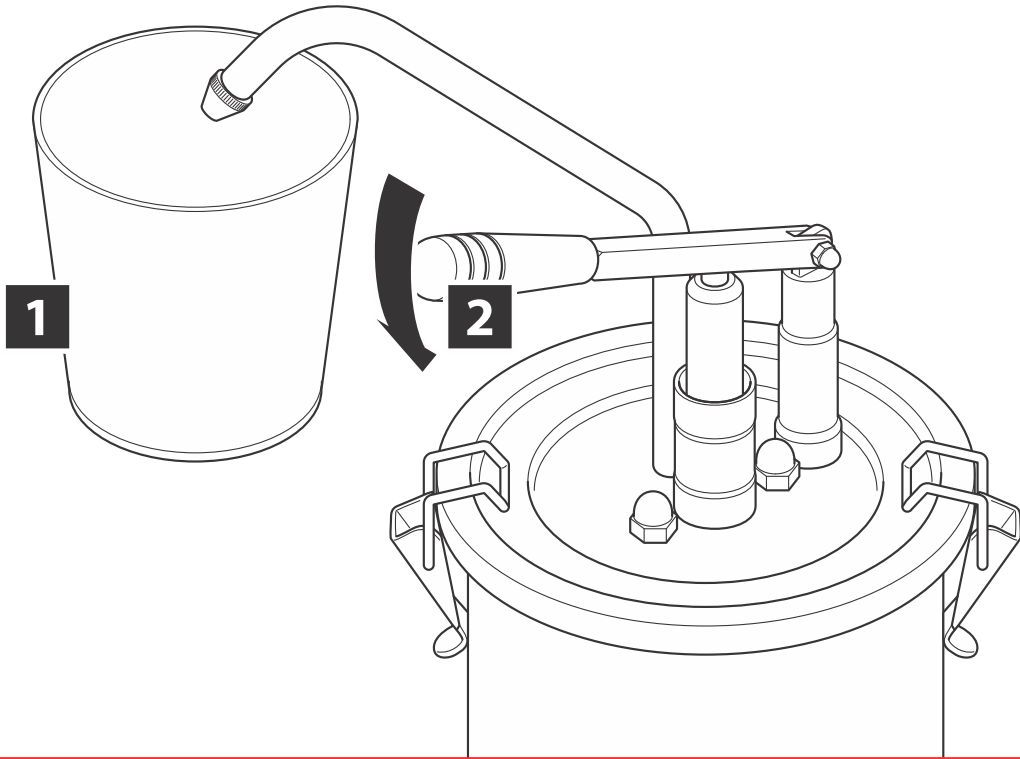

7

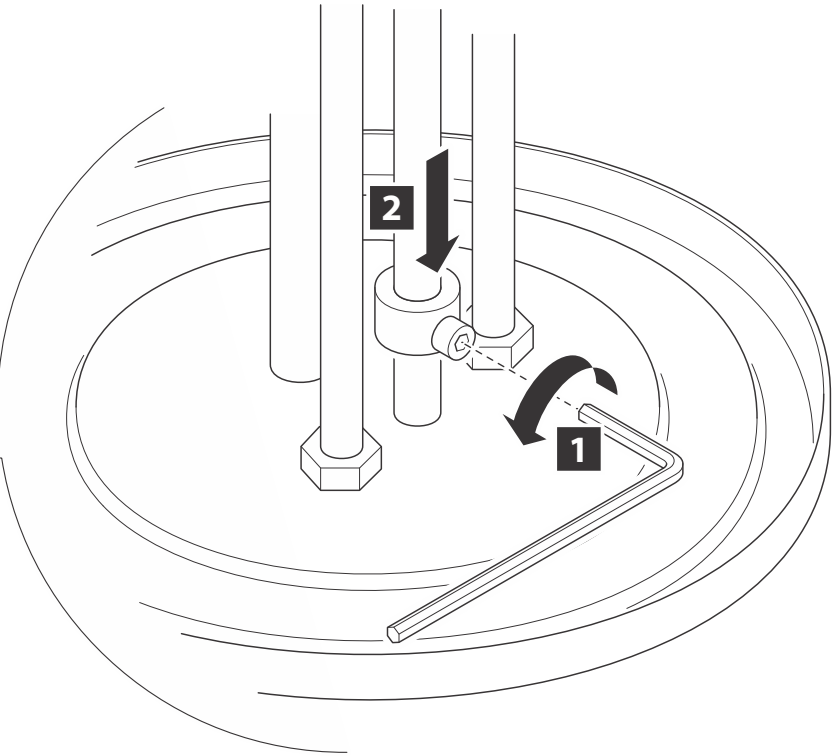
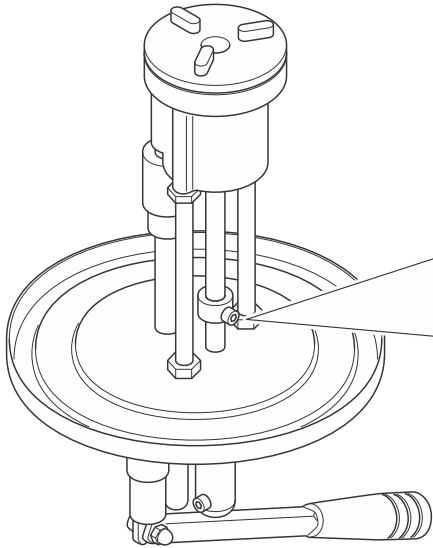

8

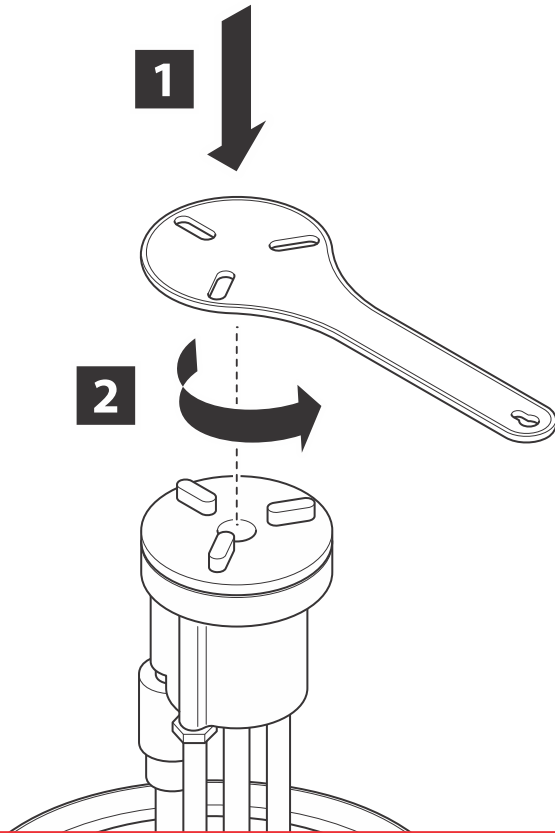

9

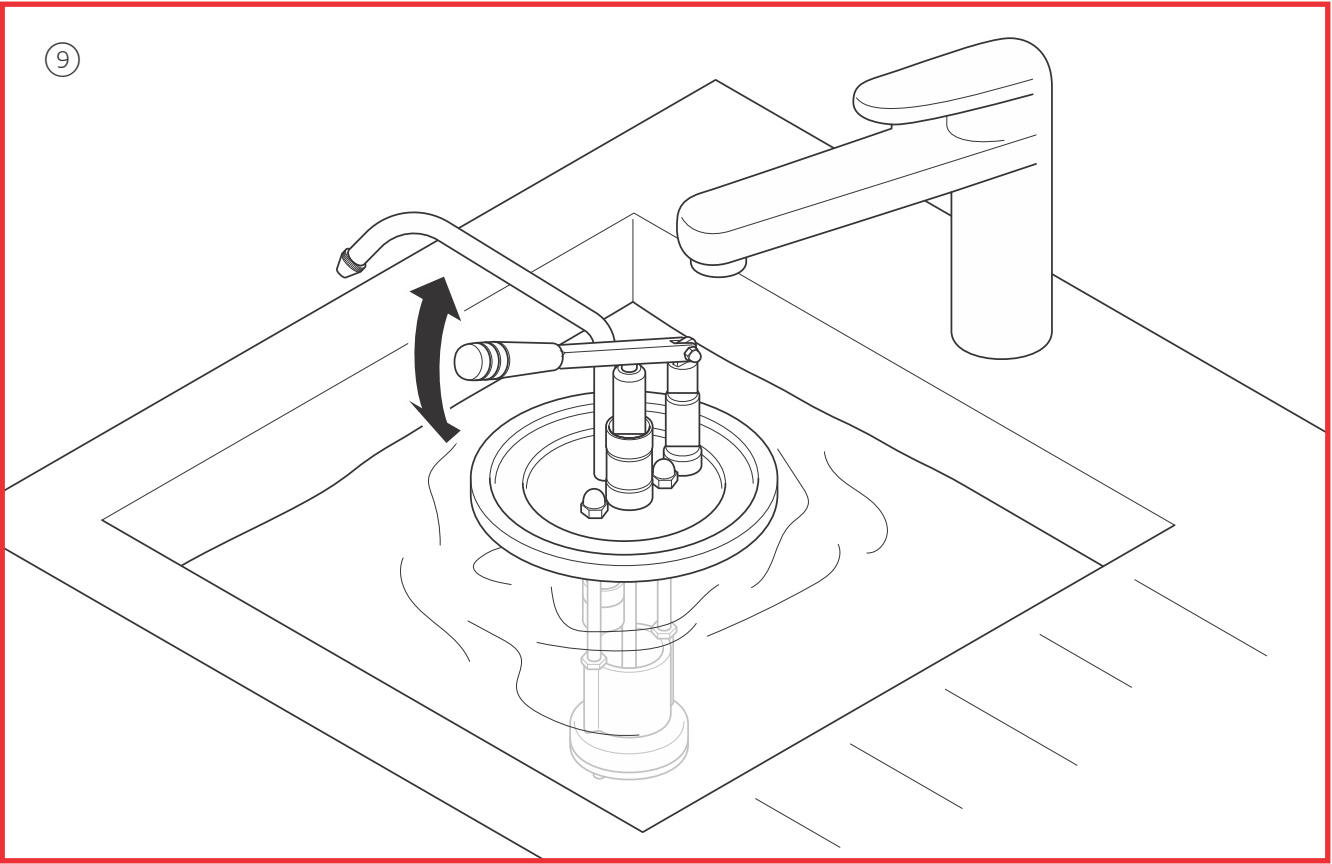

10

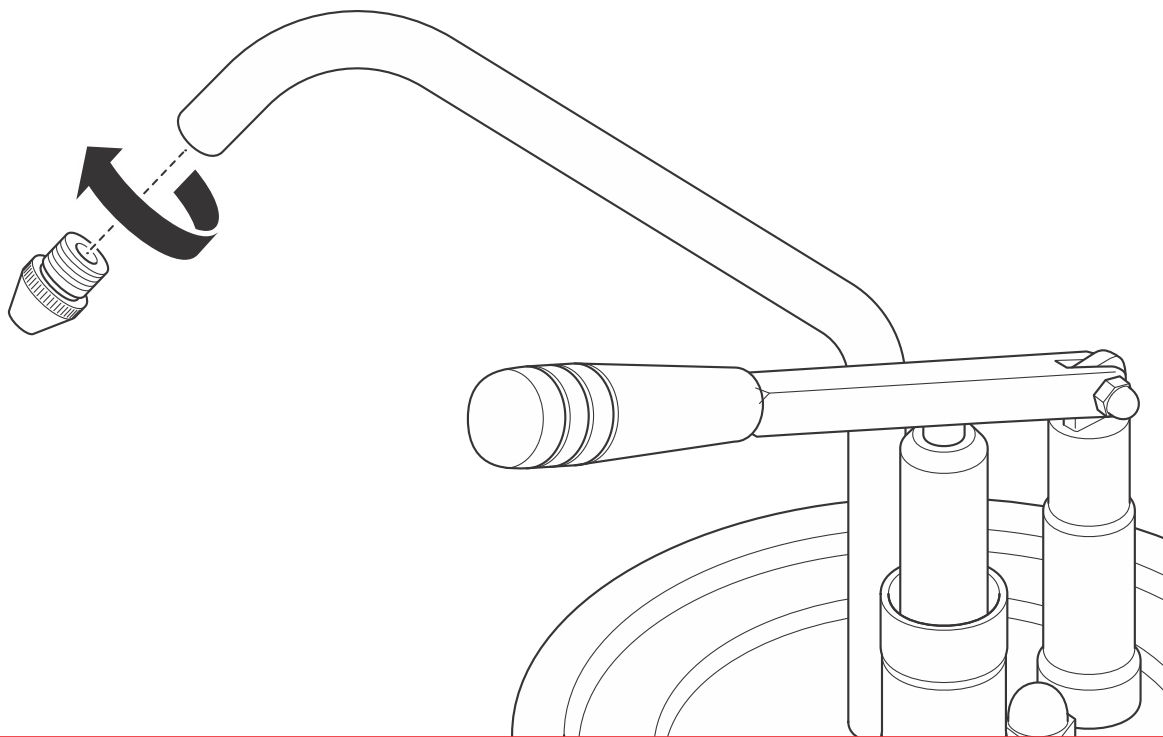

11

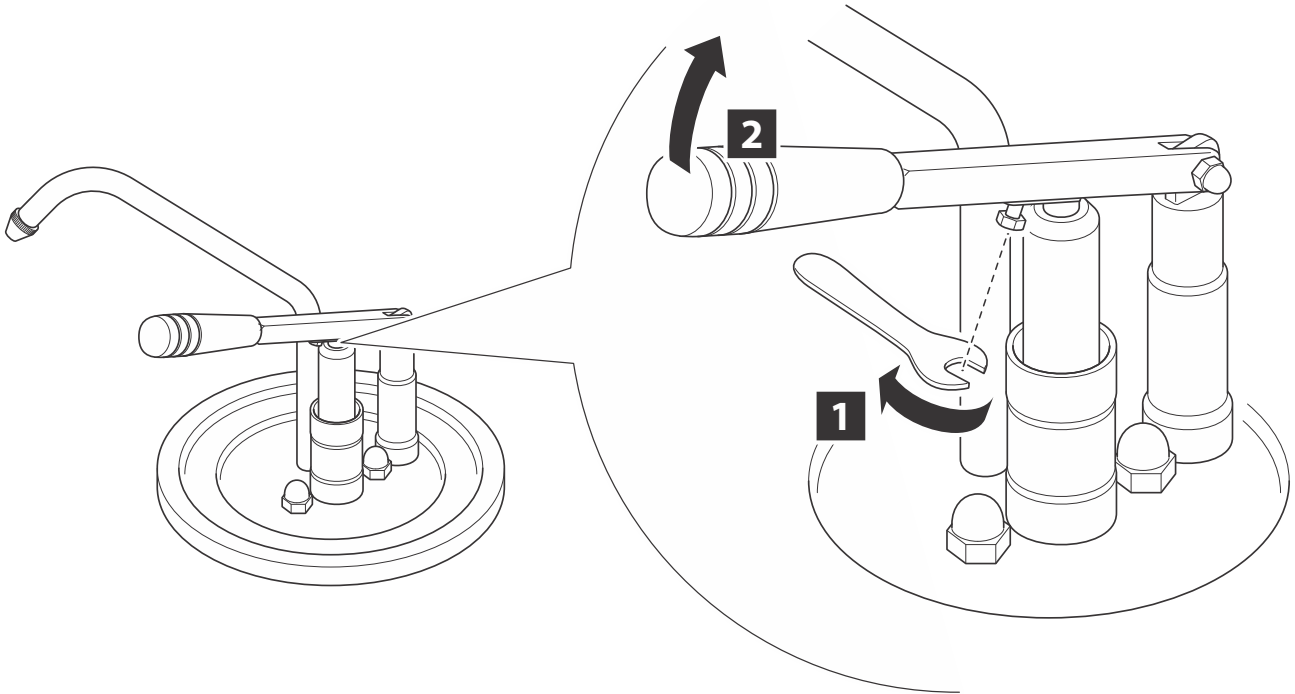

12

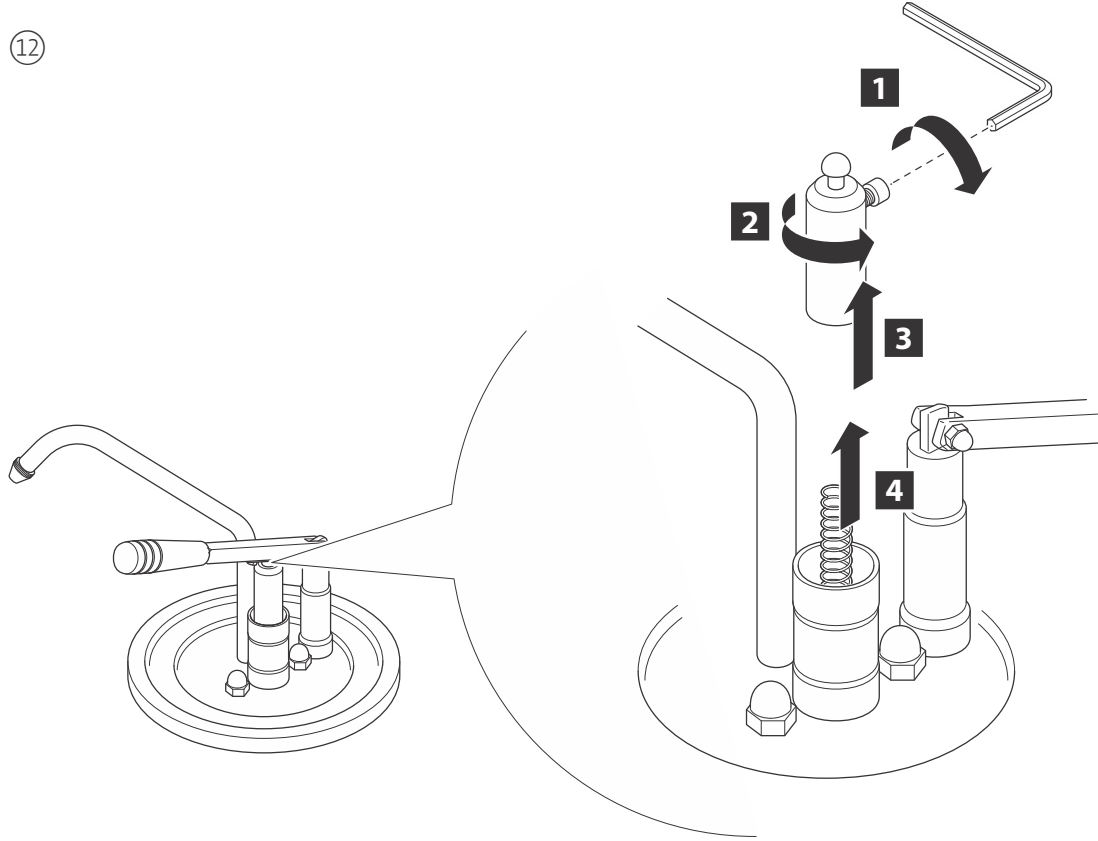

TECHNICAL SPECIFICATIONS

Lever Dispenser with 3 Ltr. Stainless Steel Locksafe Container

Item Nr / Code	Product Name	110101	KD-001-3 LEVER DISPENSER
Material		Stainless steel	
Number of pumps		1	
Capacity		3 l	
Dimensions		Ø 185 x 350 mm (h)	
Weight		1,75 kg	

PRODUCT PARTS ①

PART	LETTER
Pump Lever	A
Outlet	B
Anti-drip nozzle	C
Lid	D
Snap-on lid catches	E
Container	F
Transporting unit	G
Bottom cover	H
Dosage ring	I
Spring cap	J

EN

Locking hex bolt	K
Handle bolt	L
Allen key	M
Wrench	N
Replacement spring	O
Sauce dispenser key	P

SAFETY INSTRUCTIONS

⚠ WARNING

Please read these instructions carefully before using the **Lever Dispenser with 3 Ltr. Stainless Steel Locksafe Container**

- According to regulations on food products and safety, the majority of food products must be stored and/or served at an adequate temperature, so that they do not pose a risk to health.

- You are obliged to verify rules in force in a given country regarding food products and safety, to learn appropriate use.
- Stainless steel is one of the most suitable materials for storing and dispensing food, but many products containing acids, bases, chlorine or salts may cause corrosion.
- If rust is identified on stainless steel surfaces, try changing the washing and disinfecting agent, or change the cleaning methods used.

INTENDED USE

The KD-001 dispenser is intended to dispense ketchup, mayonnaise, mustard and other cold sauces. Every use of the appliance for a different purpose and/or in a way that diverges from the use described in this manual is not permitted and is seen as unintended use.

FILLING THE DISPENSER

1. Check to make sure the packaging contains the following components:
 - 1x KD-001 dispenser
 - 1x replacement spring
 - 1x allen key
 - 1x sauce dispenser key
 - 1x wrench
 - 1x manual
2. Open the two **snap-on lid catches** (E). ②
3. Pull the **lid** (D) of the **container** (F). **NOTICE** Make sure the **pump lever** (A), **outlet** (B), **anti-drip nozzle** (C) and **transporting unit** (G) are attached to the **lid** (D). ③
4. Wash the inside of the **container** (F) and **lid** (D) with warm water. **NOTICE** follow the instructions in paragraph “Cleaning”.
5. Fill the **container** (F) with no more than 3 litres of a suitable sauce. **NOTICE** This dispenser is designed to contain ketchup, mayonnaise, mustard and other cold sauces.
6. Lower the **transporting unit** (G) into the **container** (F). ④
7. Lock the two **snap-on lid catches** (E). ⑤

DISPENSING SAUCE

NOTICE Make sure the **container** (F) is filled with sauce and the **snap-on lid catches** (E) are locked.

1. Hold a sauce tray underneath the **anti-drip nozzle** (C). (6)
2. Press the **pump lever** (A) down until the required amount of sauce flows out of the **anti-drip nozzle** (C). (6)

Tip! To decrease the dosage volume of the sauce the **dosage ring** (I) on the transporting unit can be moved upwards.

1. Place the **allen key** (M) in the bolt on the **dosage ring** (I) and turn the **allen key** (M) counter clockwise to loosen the **dosage ring** (I). (7)
2. Move the **dosage ring** (I) towards the **lid** (D), while holding the **pump lever** (A) down. (7)
3. Screw the bolt clockwise to tighten the **dosage ring** (I) to the **transporting unit** (G). **NOTICE** The more the **dosage ring** (I) is moved towards the **lid** (D), the smaller the volume of sauce dispensed.

CLEANING

Clean the sauce dispenser and the container prior to first use and after everyday use. If needed, do it more often. Stainless steel elements may be subject to corrosion. Daily cleaning, rinsing, disinfecting and thoroughly drying is of the utmost importance. Improper handling of the appliance may cause loss of warranty on this appliance.

⚠ WARNING Health hazard due to development of germs!

- The sauce dispenser should be washed and disinfected after everyday use, observing sanitation regulations in force in a given country.

⚠ CAUTION Surface damage due to usage of inadequate washing agents.

- Never wash the sauce dispenser in a dishwasher.
- Never use sharp or pointed implements, scouring agents, pot scourers, steel sponges or steel wool.
- Use HACCP compliant cleaning agents.
- Do not use any aromatic cleaning agents.

NOTICE Make sure the **lid** (D) is removed from the **container** (F) (see step ② and ③ of 'Filling the dispenser') and both parts are rinsed thoroughly with warm running water to remove all leftover sauce.

1. Screw the **bottom cover** (H) off from the **transporting unit** (G), by using the **sauce dispenser key** (O). **NOTICE** Follow the markings showing the direction of rotation found on the **bottom cover** (H). (8)
2. Wash the **transporting unit** (G) and **bottom cover** (H) thoroughly under warm, running water.
3. Place the **transporting unit** (G) with the **lid** (D) attached into a kitchen sink and run water on to the bottom section of the **transporting unit** (G). Press the **pump lever** (A) down repeatedly at the same time. (9)
4. Screw the **bottom cover** (H) back on to the **transporting unit** (G), using the **sauce dispenser key** (P).
5. Repeat step ③ in order to clean the inside of the **transporting unit** (G). **NOTICE** keep pumping until clear water runs out of the **anti-drip nozzle** (C).
6. Screw the **anti-drip nozzle** (C) counter-clockwise off from the **outlet** (B) and clean it thoroughly under warm running water. (10)
7. Dry all elements thoroughly with a clean soft cloth or let them dry in open air, to avoid corrosion.
8. Screw the **anti-drip nozzle** (C) back into **the outlet** (B).

REPLACING THE SPRING

1. Loosen the **handle bolt** (L) completely by turning it counter-clockwise with the **wrench** (N). NOTICE the **pump lever** (A) is now detached from the **spring cap** (J). (11)
2. Loosen the **locking hex bolt** (K) by turning it counter-clockwise with the **allen key** (M). (12)
3. Turn the **spring cap** (J) counter-clockwise by hand, until it detaches from the **transporting unit** (G). (12)
4. Replace the defective spring with the **replacement spring** (O). (12)
5. Lower the **spring cap** (J) on to the spring and turn the **spring cap** (J) clockwise by hand to re-attach it to the **transporting unit** (G).
6. Tighten the **locking hex bolt** (K) by turning it clockwise.
7. Lower the **pump lever** (A) onto the **spring cap** (J) and tighten the **handle bolt** (L) completely by turning it clockwise with the **wrench** (N).

WARRANTY

Kalando hereby states and undertakes that Kalando will repair all types of damage and breakdown which may occur in the delivered products due to chronic failure and workmanship errors and defects, for a period of ONE (1) year, starting from the delivery date of the product.

EN

Kalando hereby states, accepts, and undertakes that all repair and amelioration works emerging in any manufactured materials due to workmanship defects, performance of work, poor quality of materials provided by Kalando's party, and any defects and deficiencies in assembly and production, are within the scope of Kalando's responsibility.

During the delivery acceptance stage, the customer shall check each shipment against any short delivery and packaging damages. Complaints shall be notified immediately, in written form. Information shall be demanded from the carrier with regard to the relevant situation.

The customer must to examine the goods immediately and notify Kalando of any apparent defects in written form. Latent defects shall be notified in written form immediately after relevant examination. Goods damaged during shipment, or goods whose faulty status were determined beforehand, shall by no means be repaired. Otherwise, Kalando will be exonerated from this warranty commitment.

Damage and breakdown caused by failure to comply with the operating manual after delivery, unsuitable use, wear and tear and erroneous and careless use will not be within the scope of the guarantee.

KALANDO DISPENSING SYSTEMS

İsteks San. Sit. Sosyal Merkez Binası No : 29-30
34490 Başakşehir İSTANBUL TÜRKİYE

+90 212 647 85 61

 mykalando

info@kalando.com

www.kalando.com